



Strain Gauges UBF series €€

These are foil strain gauges developed for measurement on composite materials. They have a specially designed grid pattern to reduce the stiffening effect of the strain gauges. In addition, owing to the development of gauge backing with better compliance, the number of repetition in thermal cycling test and the creep characteristics have been significantly improved compared to conventional strain gauges.



* The strain gauge of this series is not self-temperature-compensated. The thermal output should be measured prior to the actual measurement using a dummy test piece.

Please specify the type number as shown in the example below.

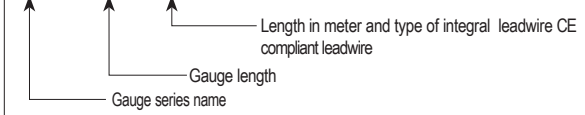
UBFLA -1 -3LJB-F



Operating temperature range	-30~+150°C	Applicable adhesives
Temperature compensation range	N/A	CN -30~+120°C
		EB-2 -30~+150°C

Gauge pattern	Type	Gauge size(mm)		Backing size(mm)		Resistance Ω
		Length	Width	Length	Width	
● Single axis						
 UBFLA-03 Q (×3)	UBFLA-03	0.3	1.9	3.4	2.5	120
 UBFLA-1 Q (×3)	UBFLA-1	1	1.3	4.5	2	120

Minimum order quantity is 10 strain gauges.
These strain gauges are available with integral leadwires attached. (made to order)



Important point

Composite materials made of plastics reinforced with glass fibers (GFRP), carbon fibers (CFRP) or aramid fibers (AFRP) have different elastic modulus and coefficient of linear thermal expansion depending on the direction of the fibers. When measuring strain on composite materials, pay enough attention to its components and the direction of the fibers.