

- Excellent energy resolution in the 3 to 300 keV range
- Active area from 30 to 1000 mm²
- PopTop flexibility
- Unequaled timing performance
- Detectors larger than 36-mm diameter available
- Available with special feedback resistor for high-rate applications
- POF preamplifier option for superior energy resolution and high count rate at low energies

The ORTEC GLP Series Planar Low-Energy Photon Spectrometer (LEPS) is a small-area, high-purity germanium photon spectrometer for use in applications over the energy range from 3 to ~300 keV.

Available in diameters from 6 to 36 mm, the LEPS offers exceptional energy resolution for low and intermediate energies. At low energies in nuclear structure physics GLP detectors are irreplaceable because of their excellent timing performance (see Table 1).

A cross sectional drawing of a 16-mm LEPS is shown in Figure 1.

The Following Specifications are Provided for Each Model GLP Detector

- Active crystal diameter and depth.
- Energy resolution at 5.9 keV photons from ⁵⁵Fe at optimum shaping time unless the window material prohibits this energy.
- Energy resolution at 122 keV photons from ⁵⁷Co at optimum shaping time.

Configuration Guidelines

PopTop or Streamline (non-PopTop) Configuration

The essence of a PopTop detector system is that the HPGe detector element, preamplifier, and high voltage filter are housed in a detector "capsule" which is then attached to an appropriate cryostat (Figure 2.)

In so called Streamline systems, the detector capsule is NOT demountable. Detector capsule and cryostat share the same vacuum. In configuration terms, this requires a cryostat or cryostat/dewar selection with the cryostat having a matching diameter to the capsule endcap. A cryostat must always be ordered with a Streamline capsule, because they are integral.

The actual PopTop capsule has its own vacuum. It can be mounted on any of the available cryostats or cryostat/dewar combinations.

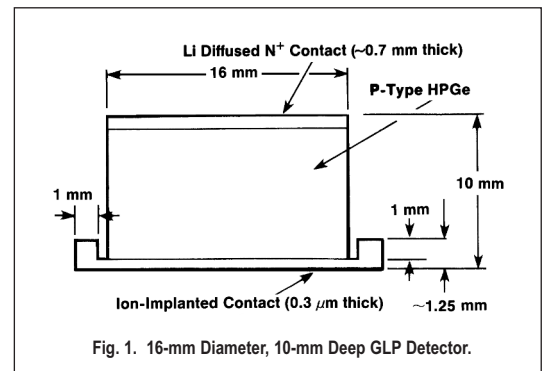

Fig. 1. 16-mm Diameter, 10-mm Deep GLP Detector.

Table 1. Timing at Low Energies with 10 cm ² Active Area Planar Detectors*.		
Source	Energy (keV)	Time Resolution(ns)
²² Na	20 ±10	20 ±2
	100 ±10	8.5 ±1
	511 ±5	4.5 ±0.2
¹³³ Ba	31 ±3	19 ±2
	81 ±3	Isomer
	85 ±5	11 ±1
¹⁵² Eu	356 ±5	6.0 ±0.5
	41 ±3	15 ±1
	122 ±5	Isomer
	125 ±5	6.5 ±0.5
	344 ±5	5.0 ±0.2
	779 ±5	3.8 ±0.3

*Data courtesy of Dr. Kim Lister, Argonne National Lab.

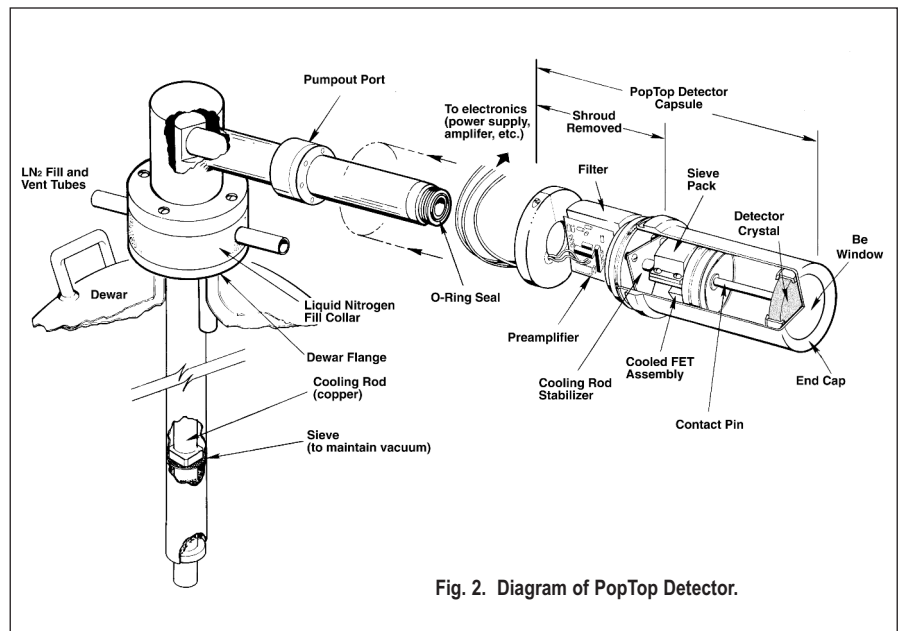

Fig. 2. Diagram of PopTop Detector.

GLP Series Planar HPGe Low-Energy Detector

Product Configuration Guide

Steps to Configure Your ORTEC HPGe Detector

1) Configure the Detector Model

- Capsule type (PopTop or Streamline)
- Crystal dimensions and specifications
- Endcap and window
- Mount
- Preamplifier
- Cable Package

Options are available for the detector model that can change specific materials used in the construction of the detector endcap, cup, and mount. Preamplifier options are also available.

2) Configure the Cryostat/Dewar Model

- Vertical Dipstick style (separate Dewar or Mobius Recycler)
- Horizontal Dipstick style (separate Dewar or Mobius Recycler)
- Portable with all-position or multi-position cryostat/dewar models
- Downlooking designed to be oriented with the detector pointing down
- Sidelooking designed to be oriented with the detector horizontal at the bottom of the dewar
- "SJ" configuration designed with the detector attached near the bottom of the dewar and a right angle bend in the cryostat orienting the detector to look up.

A cryostat and dewar or other cooling device are required for operation.

If a PopTop detector has been selected, you can choose a PopTop style cryostat or cryostat/dewar combination.

If a Streamline detector has been selected, you must choose a cryostat or cryostat/dewar model for the detector to be mounted on and vacuum sealed. The cryostat or cryostat/dewar combination diameter must match the endcap diameter of the selected detector.

Detector Options

SMART-1 Option (-SMN)

The SMART-1 option monitors and reports on vital system functions, and can save authentication codes and report the code at a later time. It has the high voltage included, so none of the instruments require an external high-voltage power supply.

The SMART-1 is housed in a rugged ABS molded plastic enclosure and is permanently attached to the detector endcap via a molded-strain-relieved sealed cable. This eliminates the possibility that the detector will suffer severe damage from moisture leaking into high-voltage connectors. The SMART-1 can be positioned in any convenient place and does not interfere with shielding or other mounting hardware.



SMART-1 Detector Interface Module.

Defining the Detector Model

Base Model (example)	PopTop or Streamline	High Voltage Option (if required)
GLP-06165/05	P4 (PopTop) (Streamline)	-SMN

GLP Series Planar HPGe Low-Energy Detector Product Configuration Guide

Streamline Detector Capsule

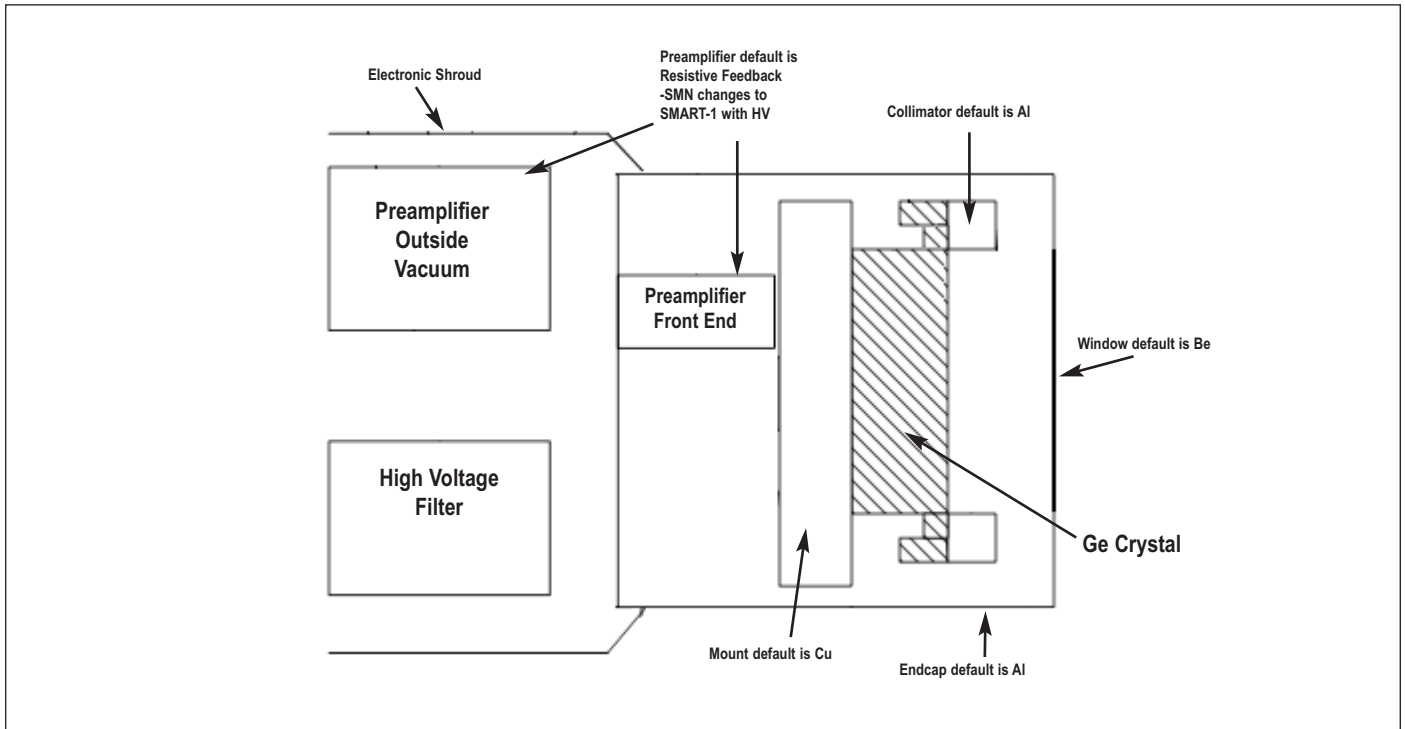

PopTop Detector Capsule

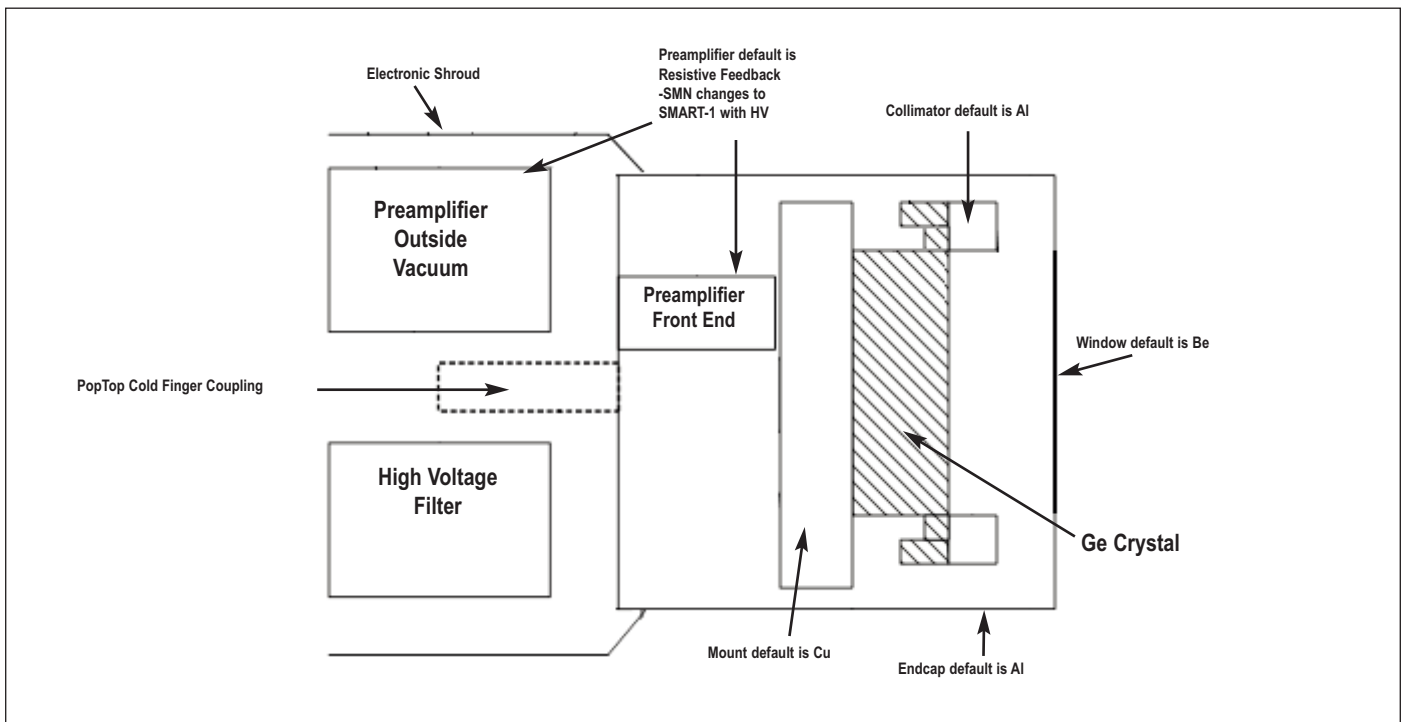

GLP Series Planar HPGe Low-Energy Detector Product Configuration Guide

Streamline Cryostat and Cryostat/Dewar Assemblies

Streamline systems (detector capsule and cryostat) share the same vacuum, requiring a cryostat or cryostat/dewar selection with the cryostat having a matching diameter to the capsule endcap.

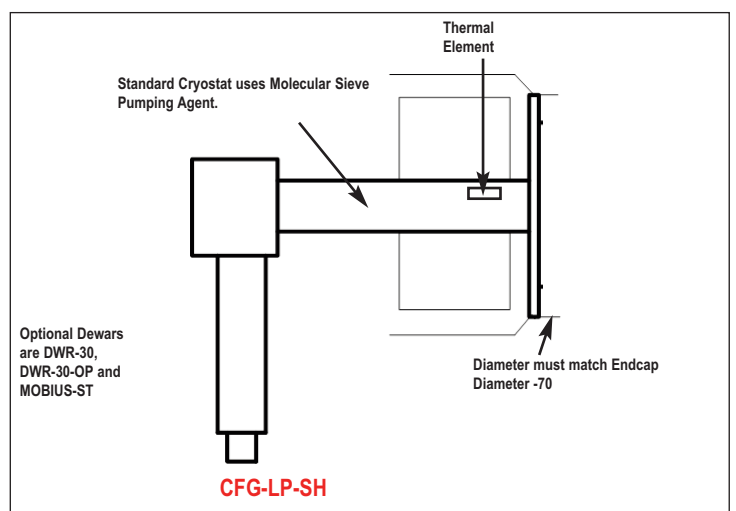
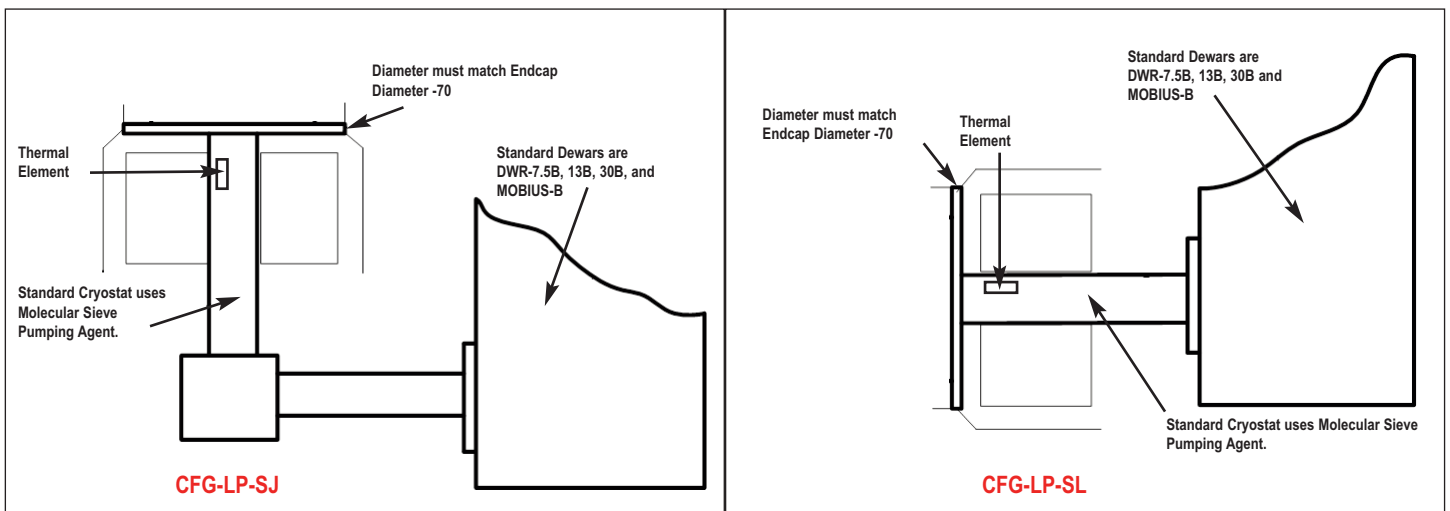
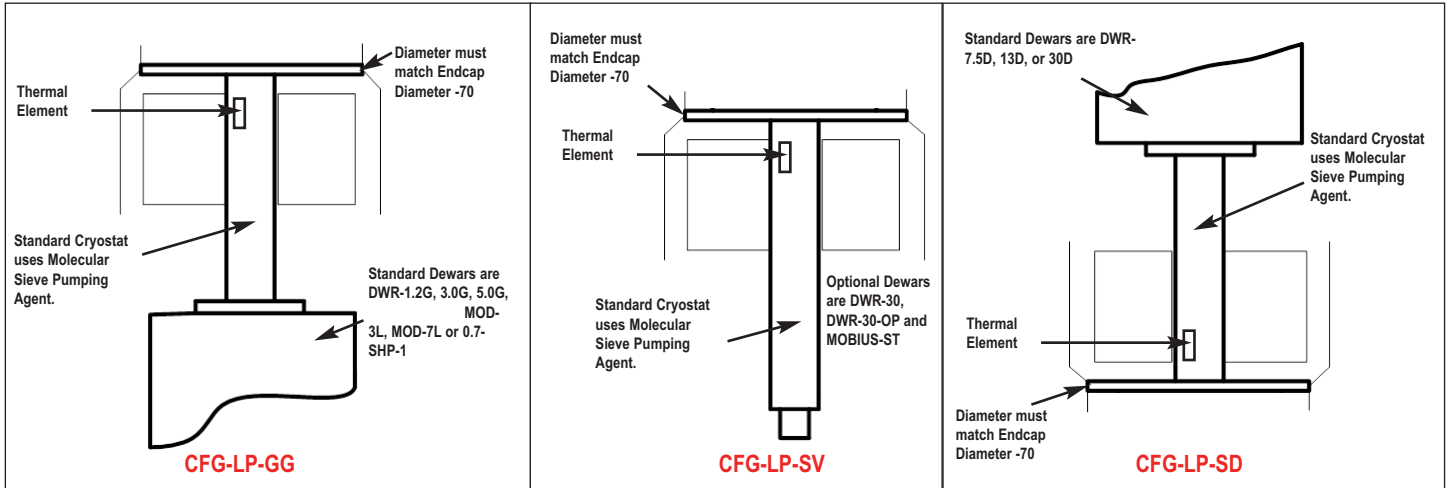

GLP Series Planar HPGe Low-Energy Detector Product Configuration Guide

PopTop and Streamline Dimensional Data

Streamline systems (detector capsule and cryostat) share the same vacuum, requiring a cryostat or cryostat/dewar selection with the cryostat having a matching diameter to the capsule endcap. A cryostat must be ordered with a Streamline capsule.

The PopTop capsule features an internal vacuum arrangement. It can be mounted on any of the available PopTop cryostats or cryostat/dewar combinations.

The cryostat and dewar drawings that follow are to be used in conjunction with the accompanying tables of dimensions.

Note: Cryostat/Dewar drawings are NOT to scale, see tables that follow for complete dimensions. Dimensions are for reference only and subject to change, if dimensional constraints are critical, contact the factory.

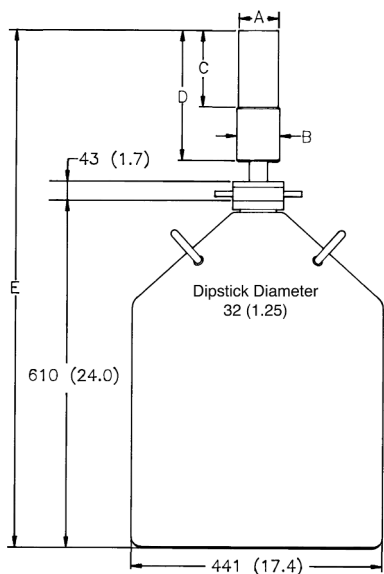

CFG-LP-SV, DWR-30

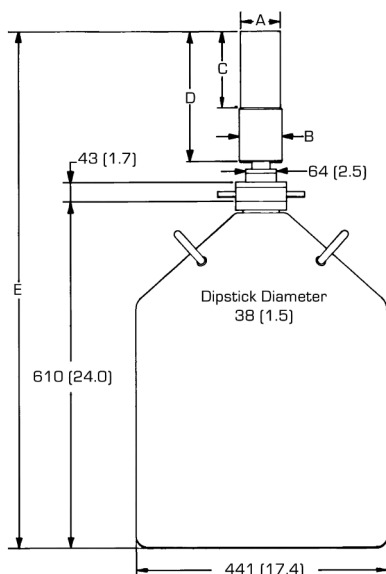

CFG-PV4, DWR-30

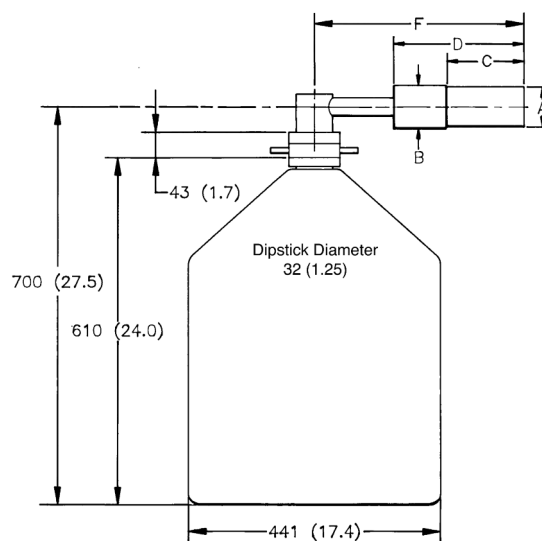

CFG-LP-SH, DWR-30

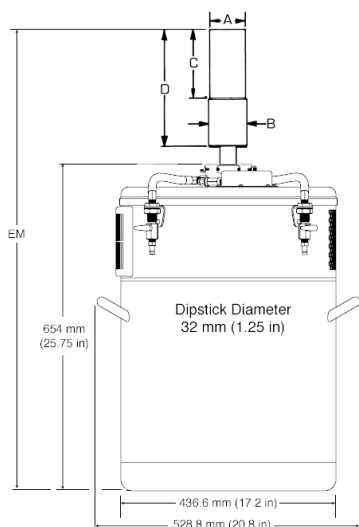

CFG-LP-SV, MOBIUS-ST

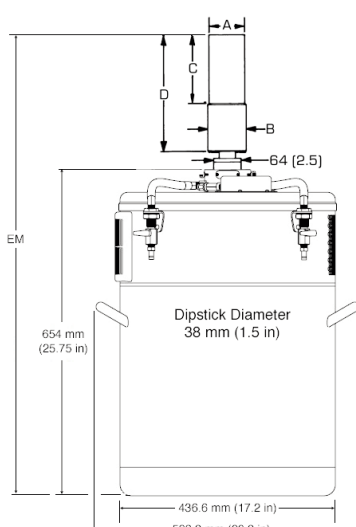

CFG-PV4, MOBIUS-PT

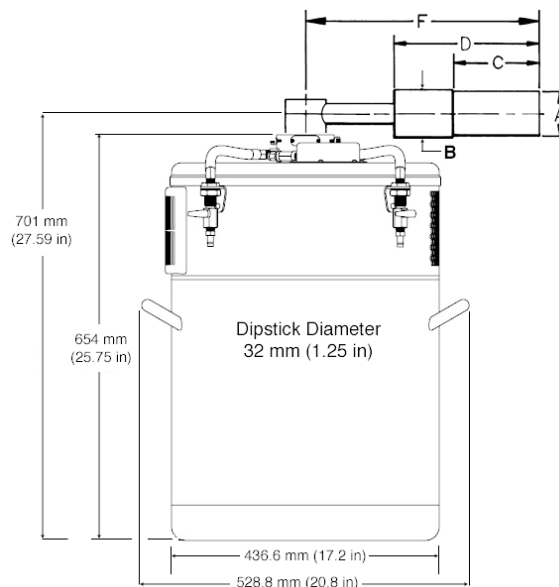

CFG-LP-SH, MOBIUS-ST

GLP Series Planar HPGe Low-Energy Detector

Product Configuration Guide

Note: Cryostat/Dewar drawings are NOT to scale, see tables that follow for complete dimensions. Dimensions are for reference only and subject to change, if dimensional constraints are critical, contact the factory.

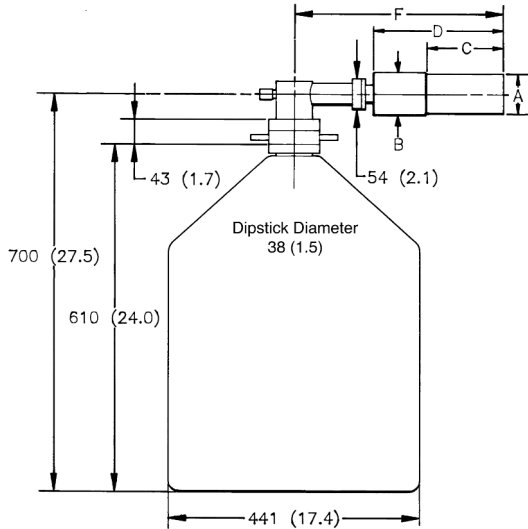

CFG-PH4, DWR-30

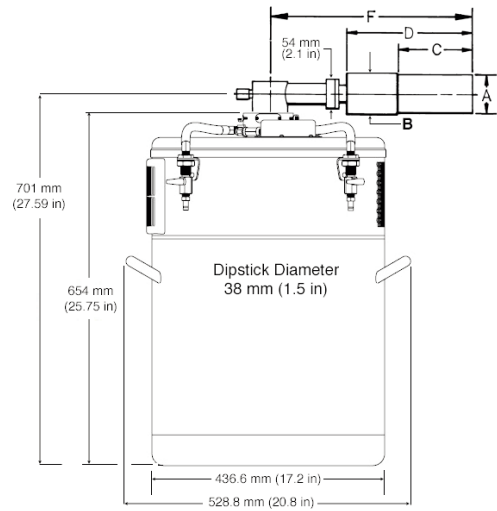

CFG-PH4, MOBIUS-PT

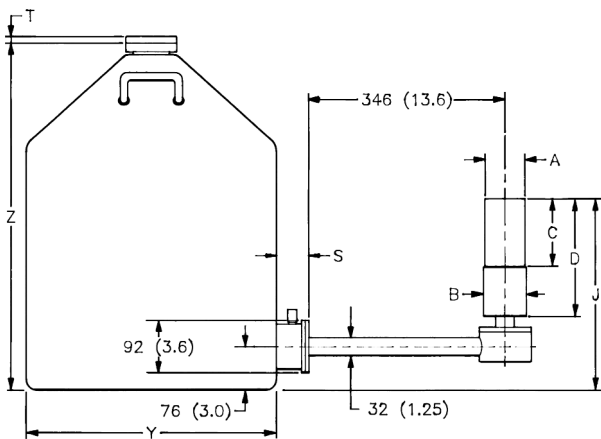

CFG-LP-SJ, DWR-30B (or -13B or -7.5B)

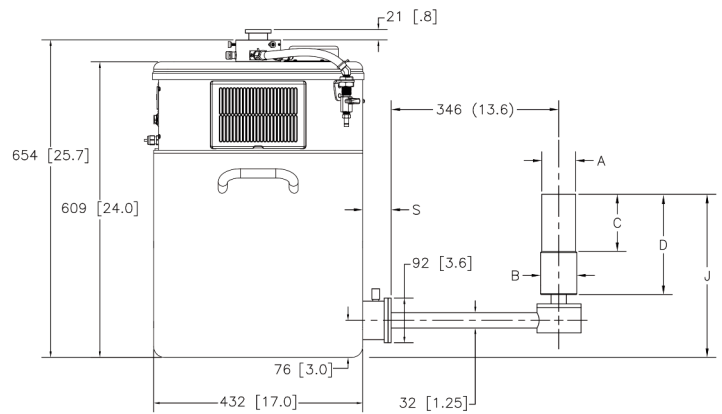

CFG-LP-SJ, MOBIUS-B

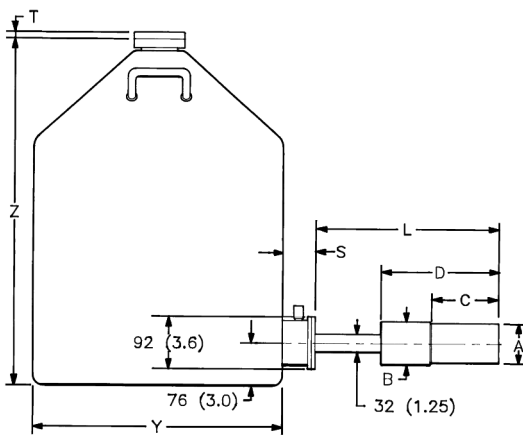

**CFG-PS4-30 (or -13 or -7.5) or
CFG-LP-SL, DWR-30B (or -13B or -7.5B)**

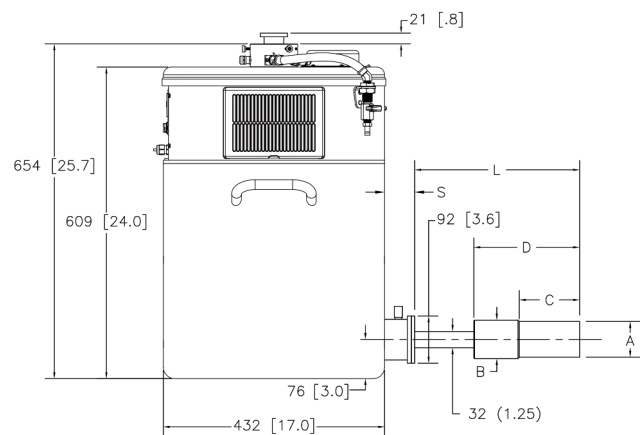

CFG-PS4-MOBIUS-B or CFG-LP-SL, MOBIUS-B

GLP Series Planar HPGe Low-Energy Detector Product Configuration Guide

**Note: Cryostat/Dewar drawings are NOT to scale, see tables that follow for complete dimensions.
Dimensions are for reference only and subject to change, if dimensional constraints are critical, contact the factory.**

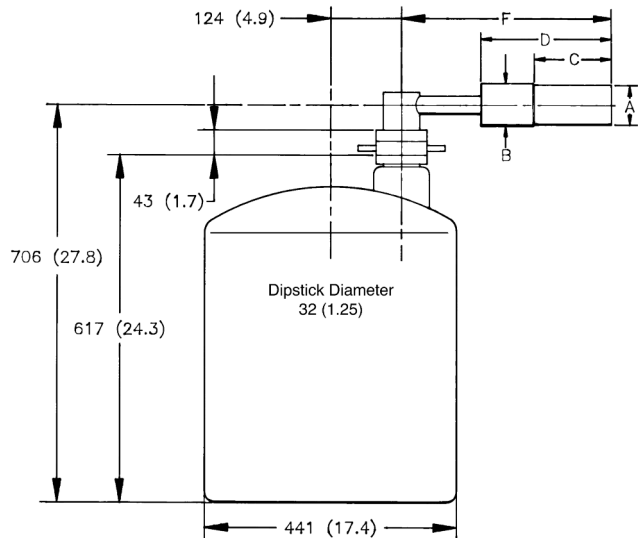

CFG-LP-SH, DWR-30-OP

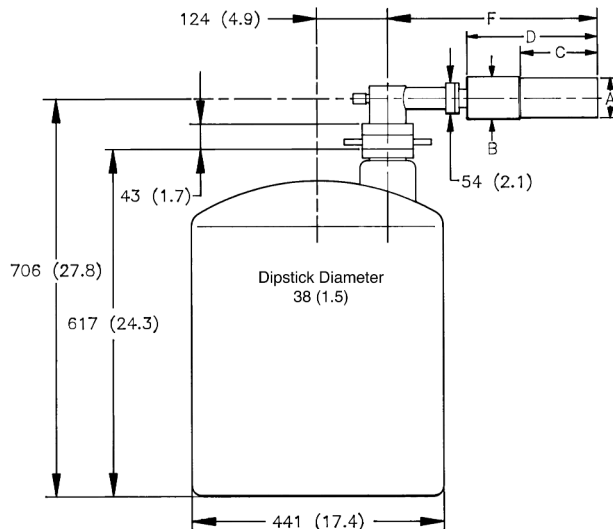

CFG-PH4, DWR-30-OP

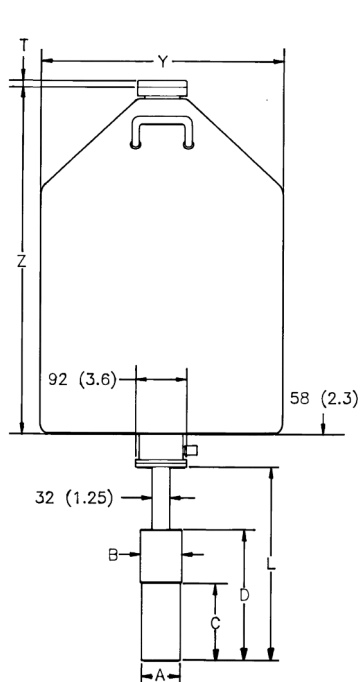

**CFG-PD4-30 (or -13 or -7.5) or
CFG-LP-SD, DWR-30D (or -13D or -7.5D)**

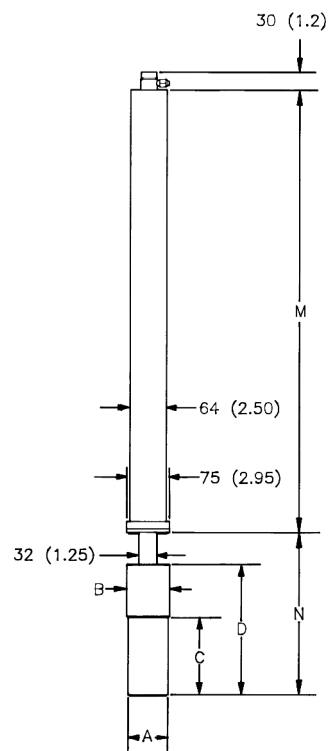

**CFG-PSHP4 or
CFG-LP-GG, DWR-0.7-SHP-1**

GLP Series Planar HPGe Low-Energy Detector

Product Configuration Guide

**Note: Cryostat/Dewar drawings are NOT to scale, see tables that follow for complete dimensions.
Dimensions are for reference only and subject to change, if dimensional constraints are critical, contact the factory.**

GLP Detector Dimensions

- Dimensions are for reference only and subject to change.
- If dimensional constraints are critical, contact the factory.

Dim.	Unit	Tol.	PopTop	Streamline
A	mm (in)	0.3 (0.01)	70 (2.75)	70 (2.75)
B	mm (in)	0.3 (0.01)	75 (2.95)	75 (2.95)
C	mm (in)	5 (0.2)	135 (5.3)	71 (2.8)
D	mm (in)	8 (0.3)	250 (9.8)	182 (7.2)
E	mm (in)	8 (0.3)	947 (37.3)	854 (33.6)
EM	mm (in)	9 (0.35)	948 (37.3)	855 (33.7)
F	mm (in)	18 (0.7)	396 (15.6)	305 (12.0)
J	mm (in)	10 (0.4)	X X	318 (12.5)
L	mm (in)	18 (0.7)	338 (13.3)	274 (10.8)
M	mm (in)	10 (0.4)	790 (31.1)	X X
N	mm (in)	8 (0.3)	278 (10.9)	215 (8.5)

GLP Series Planar HPGe Low-Energy Detector Product Configuration Guide

**Note: Cryostat/Dewar drawings are NOT to scale, see tables that follow for complete dimensions.
Dimensions are for reference only and subject to change, if dimensional constraints are critical, contact the factory.**

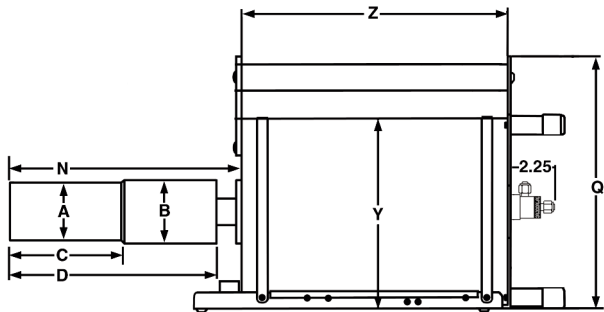

**CFG-PG4-1.2 (or -3 or -5) or
CFG-LP-GG, DWR-1.2G (or -3.0G, -5.0G)**

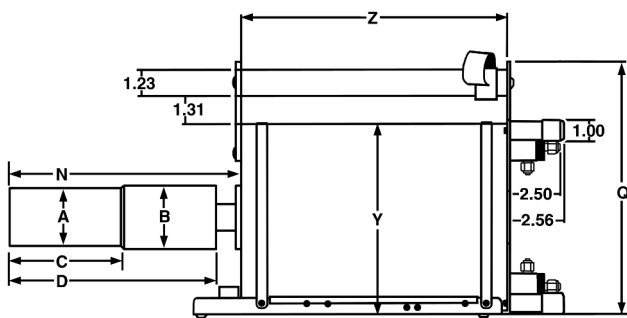

**CFG-PMOD4-3 (or -7) or
CFG-LP-GG, DWR-MOD3L (or -MOD7L)**

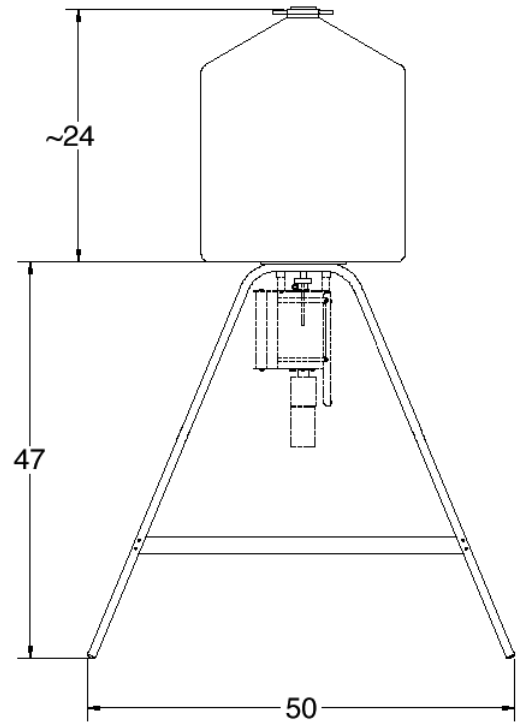

DWR-S/F

Gamma Gage and Side-Looking Dewar Dimensions

- Dimensions are for reference only and subject to change.
- If dimensional constraints are critical, contact the factory.

			Cryostat/Dewar or Dewar Type							
			CFG-PG4 and DWR-x.xG			CFG-PMOD4 and DWR-MOD-xL		CFG-PS4, CFG-PD4, DWR-xxB and DWR-xxD		
			VOLUME			VOLUME		VOLUME		
Dim.	UNIT	TOL. ±	1.2L	3L	5L	3L	7L	7.5L	13L	30L
Q	mm (in)	13 (0.5)	229 (9.0)	302 (11.9)	302 (11.9)	229 (9.0)	302 (11.9)	X X	X X	X X
S	mm (in)	7.6 (0.3)	X X	X X	X X	X X	X X	77 (3.0)	77 (3.0)	60 (2.3)
T	mm (in)	5 (0.2)	X X	X X	X X	X X	X X	10 (0.4)	10 (0.4)	13 (0.5)
Y	mm (in)	13 (0.5)	157 (6.2)	229 (9.0)	229 (9.0)	157 (6.2)	229 (9.0)	224 (8.8)	307 (12.1)	442 (17.4)
Z	mm (in)	5 (0.2)	229 (9.0)	267 (10.5)	419 (16.5)	292 (11.5)	320 (12.6)	452 (17.8)	429 (16.9)	610 (24.0)

GLP Series Planar HPGe Low-Energy Detector

Product Configuration Guide

Example Model Numbers

Streamline Configuration

GLP-06165/05	6-mm diameter, 5-mm deep GLP planar detector with 70-mm diameter endcap.
CFG-LP-GG-70	Portable Gamma Gage cryostat with matching 70-mm diameter flange.
DWR-1.2G	1.2 liter all-position dewar for Gamma Gage cryostat.

GLP-36385/10	36-mm diameter, 10-mm deep GLP detector with 70-mm diameter endcap.
CFG-LP-SD-70	Downlooking cryostat with matching 70-mm diameter flange.
DWR-7.5D	7.5 Liter downlooking dewar for downlooking cryostat.

GLP-16195/10-SMN	16-mm diameter, 10-mm deep GLP detector with 70-mm diameter endcap and SMART-1 preamplifier and high voltage supply.
CFG-LP-SV-70	Vertical "dipstick" style cryostat with matching 70-mm diameter flange.
DWR-30	30 liter top port dewar that accepts "dipstick" style cryostats.

PopTop Configuration

GLP-36360/13P4-SMN	36-mm diameter, 13-mm deep GLP detector with 70-mm diameter endcap and SMART-1 preamplifier and high voltage supply.
CFG-PG-3	Portable Gamma Gage cryostat with 3 liter all-position dewar.

GLP-10180/07P4	10-mm diameter, 7-mm deep GLP detector with 70-mm diameter endcap.
CFG-PD4-7.5	Downlooking cryostat with 7.5 liter dewar.

GLP-06165/05P4	6-mm diameter, 5-mm deep GLP planar detector with 70-mm diameter endcap.
CFG-PH4	Horizontal Dipstick type cryostat.
MOBIUS-PT	Möbius Recycler.

GLP Series Planar HPGe Low-Energy Detector Product Configuration Guide

Ordering Information

- For Streamline, remove the “P4” from the model number.
- If dimensional considerations are critical, contact factory.
- Cryostat and dewar or other cooling device are not included with detector.
- Cryostat and dewar or other cooling device are required for operation.
- A cryostat must be ordered with a Streamline detector.

Model No.	Active Diameter (mm)	Dimensions		Energy Resolution FWHM		Endcap Diameter (mm)	Be Window Thickness (mm)
		Area (mm ²)	Depth (mm)	@5.9 keV (eV)	@122 keV (eV)		
GLP-06165/05P4	≥6	≥28	≥5	≤165	≤480	70	0.13
GLP-10180/07P4	10	80	7	180	485	70	0.13
GLP-16195/10P4	16	200	10	205	525	70	0.13
GLP-25325/10P4	25	500	10	325	550	70	0.25
GLP-25300/13P4	25	500	13	300	545	70	0.25
GLP-32355/10P4	32	800	10	355	580	70	0.25
GLP-32340/13P4	32	800	13	340	570	70	0.25
GLP-36385/10P4	36	1000	10	385	595	70	0.25
GLP-36360/13P4	36	1000	13	360	585	70	0.25

GLP Detector Options

-SMN SMART-1 detector option for negative bias detector, add “-SMN” to the model number.

GLP PopTop Cryostats and Dewars

Model No.	Description
CFG-PD4-7.5	Down-looking Cryostat with 7.5-liter Dewar
CFG-PD4-13	Down-looking Cryostat with 13-liter Dewar
CFG-PD4-30	Down-looking Cryostat with 30-liter Dewar
CFG-PG4-1.2	Gamma Gage Cryostat with 1.2-liter Dewar
CFG-PG4-3	Gamma Gage Cryostat with 3-liter Dewar
CFG-PG4-5	Gamma Gage Cryostat with 5-liter Dewar
CFG-PH4	Horizontal Cryostat (Dipstick type). Choose DWR-30, DWR-30-OP, MOBIUS-PT or MOBIUS-PT-DET.
CFG-PMOD4-3	Gamma Gage Cryostat with 3-liter Multi-Orientation Dewar
CFG-PMOD4-7	Gamma Gage Cryostat with 7-liter Multi-Orientation Dewar
CFG-PS4-7.5	Side-Looking Cryostat with 7.5-liter Dewar
CFG-PS4-13	Side-Looking Cryostat with 13-liter Dewar
CFG-PS4-30	Side-Looking Cryostat with 30-liter Dewar
CFG-PS4-MOBIUS-B	Side-Looking Cryostat with Möbius Recycler 28-liter Dewar
CFG-PS4-MOBIUS-B-DET	Side-Looking Cryostat with Möbius Recycler 28-liter Dewar for purchase in combination with PopTop detector.
CFG-PSHP4	Down-Looking Shallow-Hole Probe with 0.7-liter Dewar
CFG-PV4	Vertical Cryostat (Dipstick type). Choose DWR-30, DWR-30-OP, MOBIUS-PT or MOBIUS-PT-DET.
MOBIUS-PT	Möbius Recycler.
MOBIUS-PT-DET	Möbius Recycler 28-liter Dewar for purchase in combination with PopTop detector and vertical or horizontal dipstick cryostat.
DWR-30	30-liter Dewar
DWR-30-OP	30-liter Offset-Port Dewar
DWR-S/F	Storage Fill Dewar for CFG-PG4-X

GLP Series Planar HPGe Low-Energy Detector Product Configuration Guide

GLP Streamline Cryostats

• Dewar required. Select dewar from GLP Streamline Dewars.

Model No.	Description
CFG-LP-GG-70	Gamma Gage Cryostat
CFG-LP-SD-70	Down-Looking Cryostat
CFG-LP-SH-70	Horizontal Cryostat (Dipstick type).
CFG-LP-SJ-70	J-type Cryostat
CFG-LP-SL-70	Side-Looking Cryostat
CFG-LP-SV-70	Vertical Cryostat with (Dipstick type).

GLP Streamline Dewars

For Cryostat	Choose	Description
CFG-LP-GG	DWR-1.2G	1.2-liter All-Orientation Dewar
	DWR-3.0G	3.0-liter All-Orientation Dewar
	DWR-5.0G	5.0-liter All-Orientation Dewar
	DWR-MOD-3L	3-liter Multi-Orientation Dewar
	DWR-MOD-7L	7-liter Multi-Orientation Dewar
	DWR-0.7-SHP-G	0.7-liter Shallow-Hole Probe Dewar
	DWR-S/F	Storage/Fill Dewar for DWR-XG
CFG-LP-SJ, SL	DWR-7.5B	7.5-liter Side-Looking Dewar
	DWR-13B	13-liter Side-Looking Dewar
	DWR-30B	30-liter Side-Looking Dewar
	MOBIUS-B	Möbius Recycler 28-liter Side-Looking Dewar
CFG-LP-SD	DWR-7.5D	7.5-liter Down-Looking Dewar
	DWR-13D	13-liter Down-Looking Dewar
	DWR-30D	30-liter Down-Looking Dewar
CFG-LP-SV, SH	DWR-30-OP	30-liter Offset-Port Dewar
	DWR-30	30-liter Dewar
	MOBIUS-ST	Möbius Recycler 28-liter Dewar for purchase stand alone
	MOBIUS-ST-DET	Möbius Recycler 28-liter Dewar for purchase in combination with Detector

Specifications subject to change
101920